

XJC-608T-F

Common function operation instructions

Key Description

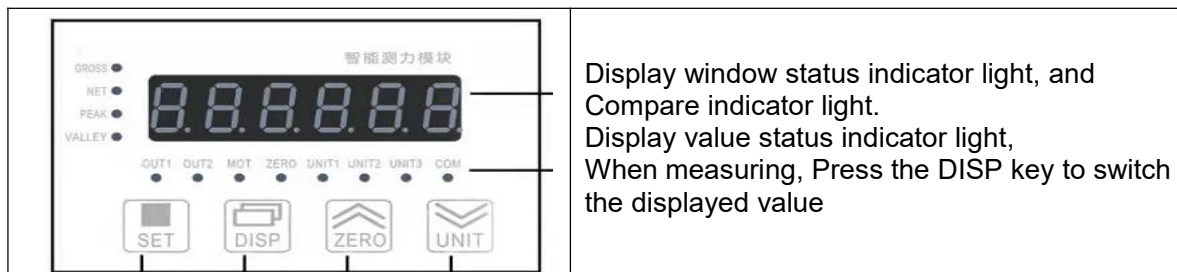

Display window status indicator light, and Compare indicator light.
 Display value status indicator light,
 When measuring, Press the DISP key to switch the displayed value

No.	Name	Description
1	display window	In measurement state, the measured value is displayed; In setting state, display the parameter symbol, parameter value;
2	Status Indicator light	GROSS
2		NET
2		PEAK
2		VALLEY
3	Comparison output and change indicator light	OUT1
3		OUT2
3		MOT
3		ZERO
4	SET Key	In measurement state, press and hold for more than 2 seconds to enter the setting; In setting state, when the parameter symbol is displayed: press and hold for more than 2 seconds to enter the next set of parameters; In setting state, when the parameter symbol is displayed: switch to the next parameter; When revise the parameter value: save the modified parameter value;
5	DISP Key	In measurement state, switch the display (see the description of the status indicator above for details) Press and hold for 2 seconds in the measurement state to clear the alarm code In setting state, when the parameter symbol is displayed: call the original parameter value When revise the parameter value: move modifier bits
6	ZERO Key	In measurement state, zero and clear peak-to-valley value; In setting state, when the parameter symbol is displayed: switch to the previous parameter; When revise the parameter value: increase the value of the parameter;
7	UNIT Key	In measurement state, switch the display unit; In measurement state, press and hold for 2 seconds to clear the peak-to-valley value; In setting state, when the parameter symbol is displayed: switch to the next parameter; When revise parameter value: decrease the value of the parameter
8	unit indicator light	UNIT
9	Communication indicator light	COM

Wiring Instructions

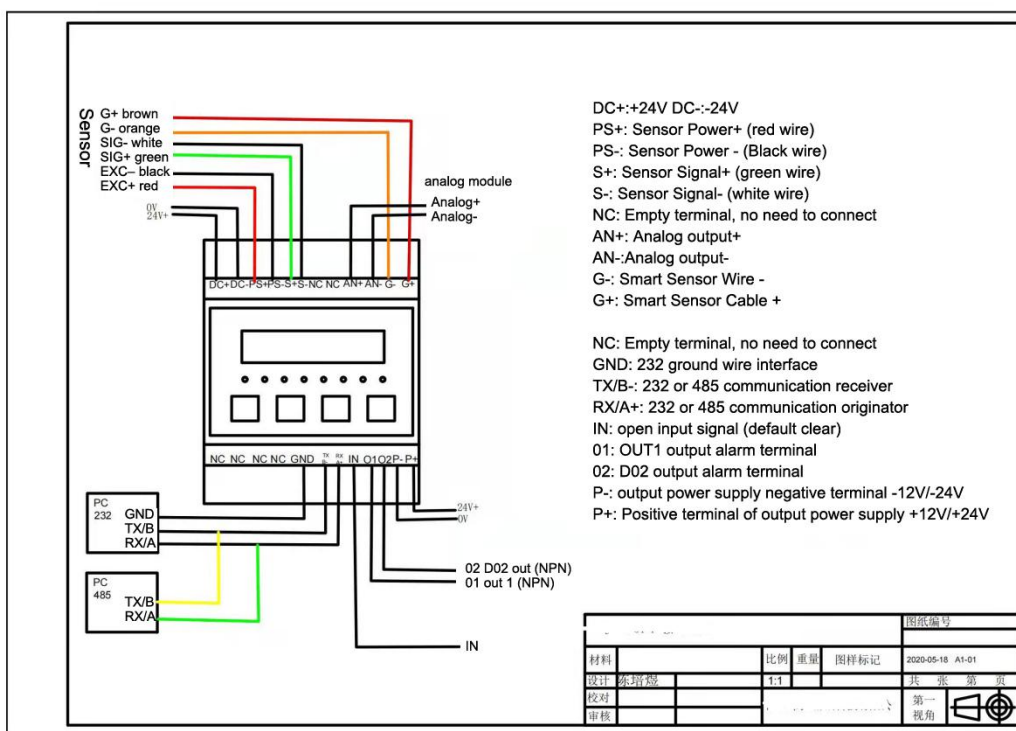

Instrument error description

- (1) **ERROR1:** During zero operation, the current weight display is unstable or exceeds the set value of the reset range parameter, and the reset operation fails.
- (2) **ERROR2:** It means that the gain mV value during gain calibration CALF \leq the zero mV value CAL0 during zero calibration.
- (3) **ERROR3:** The maximum range Fr of the instrument is not set properly, $(Fr/Fd) < 100$ or $(Fr/Fd) > 200000$.
- (4) **ERROR4:** The gain is too low to cause instability or error in the display, or the sensitivity is too low.
- (5) **ERROR5:** The polyline parameters do not meet the requirements.

Instrument Parameter Setting Catalog

Chapter 1. Group 1 of parameter functions and settings of the instrument entering the 1111 password (01-20)

- 1.1 Set the decimal point position
- 1.2 Set the zero tracking range and time
- 1.3 Set the zero range
- 1.4 Setting the digital filter constant and fluctuation detection threshold
- 1.5 Setting the Measurement Correction Judgment Threshold and Measurement Correction Value
- 1.6 Measurement rate selection
- 1.7 peak-to-valley value detection settings
- 1.8 Switch input function and power-on reset function selection

Chapter 2. The instrument enters the 1111 password group 2 parameter analog output setting (30-34)

- 2.1 Analog output setting

Chapter 3. The instrument enters 1111 password group 3 parameter communication settings (40-48)

- **3.1. Instrument communication settings**

Chapter 4. Instrument entry 1111 password Group 4 parameter broken line correction setting (50-71)

- **4.1. Polyline correction parameter setting**

Chapter 4. The instrument enters the 1111 password group 4 parameter calibration parameters (80-90)

- **5.1 Sensitivity calibration**
- **5.2 Weight Calibration**

Chapter 6. Switch quantity output settings









- **6.1. Switch quantity output setting**

Chapter 7. Meter entry password 2027 User backup parameters, restore user backup parameters, restore factory settings

- **7.1 User Backup Parameters**
- **7.2 Restore user backup parameters**
- **7.3 Factory reset**

Chapter 1 Basic Parameter Setting

1.1 Set the decimal point position













				
Pressure value display interface, Press and hold the SET key (about 2s) to display AL01.	Press ZERO key once to display 990A.	Press DISP key once to display 0000.	Change to 1111 with the DISP key (switch position) and ZERO key (add number).	Press SET key once to display 01iN-d.
				
Press the DISP key to enter and display 000000.	Press the ZERO key to toggle the decimal point position (eg 2 decimal places).	The figure shows two decimal points, press the SET key to save.	As shown, the operation is completed, long press the SET key to exit.	

Remarks: If the decimal point position is changed on the original basis.

If the instrument is 0-10V ($\pm 10V$) analog output, the values of the upper and lower limits of the analog output also need to be modified accordingly.

If the instrument is 4-20mA analog output, modify the value of the upper limit of analog output (refer to Chapter 2 for operation), and the values of 85cAlp and 89Fr also need to be modified accordingly. (Refer to Chapter 5 for instructions. Do not enter the 84CALF parameter when the weight is calibrated).

1.2 Set the zero tracking range and time (refer to 7.1.2 of the manual)

				
Pressure value display interface, Press and hold the SET key (about 2 seconds) to display AL01.	Press ZERO key once to display 990A.	Press DISP key once to display 0000.	Change to 1111 with the DISP key (switch position) and ZERO key (add number).	Press SET key once to display 01in-d.
				
Press the UNIT key to switch parameters.	As shown in the figure, press the DISP key to enter, and display 000.	Zero tracking value can be set within the range; The instrument displays the last 3 digits of the max range.	If set to 010, press the SET key to save.	As shown, press the DISP key to enter.
				
Zero tracking time, set as 01.0 seconds as shown, press SET key to save.	As shown, the operation is completed, long press the SET key to exit.			





Summary: When the instrument shows that the current pressure value is within the range of the zero-point tracking set value, it will be cleared within the zero-point tracking time. As shown in the figure, the zero tracking range is 10. When the meter displays within 10, the meter will be cleared in 1.0 seconds.





Purpose: In order to overcome the zero jump of the machine structure to the sensor.

Remark: Zero tracking setting value can be used as a reference according to the on-site pressure value jumping.

Zero tracking time can be set up to 10.0 seconds. (The time can be set according to the actual situation)

1.3 Set zero range (refer to 7.1.2 of the manual)

				
Pressure value display interface, Press and hold the SET	Press ZERO key once to display 990A.	Press DISP key once to display 0000.	Change to 1111 with the DISP key (to switch positions) and the	Press SET key once to display 01in-d.

key (about 2 seconds) to display ALO1.			ZERO key (to add a number).	
				
Press the UNIT key to switch parameters.	As shown, press DISP key to enter	The maximum can be set to 99, press the SET key to save.	As shown, the operation is completed, long press SET key to exit.	

Remarks: The set value of the zero range (unit: %) is set according to the percentage of the max display range of the instrument.

1.4 Set the digital filter constant and fluctuation detection threshold (refer to 7.1.3 of the manual)

				
Pressure value display interface, Press and hold the SET key (about 2s) to display ALO1.	Press ZERO key once to display 990A.	Press DISP key once to display 0000.	Change to 1111 with the DISP key (switch position) and ZERO key (add number).	Press SET key once to display 01in-d.
				
Press the UNIT key to switch parameters.	As shown in the figure, press DISP key once to enter, and display 01.	The max can be set to 20, press SET key to save, display 07notn	Press DISP key to enter, display 021	The max can be set to 200, press the SET key to save.
				
As shown, press the DISP key to enter. Show 01	The max can be set to 10, press SET key to save.	As shown, the operation is successful, long press SET key to exit.		

Remark:

06FLtr The parameter value can be selected according to the vibration of the sensor when the force is applied (the default is 01), so that the meter display is stable.

07notn The default value of the parameter is 021 (unit: division) within 1s (when set to 0, no change judgment will be made)

08ArmA The default value of the parameter is 01 (can be used with the 06FLtr parameter)

Purpose:

06FLtr In order to overcome the vibration of the sensor under the influence of the outside world, the parameters make the instrument display stable.

07notn The parameter is cleared when the force overcomes the operation error. (When the change of the measured value exceeds the set value of this parameter, the measured value is changing, and the zero-clearing and zero-point tracking functions are not performed at this time.)

08ArmA The parameter advantages have good suppression of periodic interference and high smoothness.

1.5 Set the measurement correction judgment threshold and measurement correction value (refer to 7.1.3 of the manual)





				
Pressure value display interface, Press and hold SET key (about 2 seconds) to display AL01.	Press ZERO key once to display 990A.	Press DISP key once to display 0000.	Change to 1111 with DISP key (switch position) and ZERO key (add number).	Press SET key once to display 01in-d.
				
Press the UNIT key to switch parameters.	As shown, press DISP key to enter, display 000000	Value range -199999~999999 Press SET key to save	As shown, press DISP key to enter, display 000000	Value range -199999~999999 Press SET key to save
				
As shown, the operation is successful, long press the SET key to exit.				

Remarks: When the measured value \geq 09Moth set value, the meter display value = measured value + 10Mov (set value).

(The value range is set according to the actual situation)

Purpose: In order to overcome the hard force generated by the mechanism.

1.6 Measurement rate selection (refer to manual 7.1.3)

				
Pressure value display interface, long press the SET key (about 2 seconds) to display AL01.	Press ZERO key once to display 990A.	Press DISP key once to display 0000.	Change to 1111 with the DISP key (switch position) and ZERO key (add number).	Press SET key once to display 01in-d.

Press UNIT key to switch parameters.	As shown, press DISP key to enter, display 960	The default is 960, press SET key to save.	As shown, the operation is successful, long press SET key to exit.	

Remarks: The output sampling rate of the instrument is 12SPS. The parameter value range is 15, 120, 240, 480, 960, 1920 (unit: times/second)

1.7 Peak-to-valley value detection settings (refer to 7.1.4 of the manual)

Pressure value display interface, long press the SET key (about 2 seconds) to display AL01.	Press ZERO key once to display 990A.	Press DISP key once to display 0000.	Change to 1111 with the DISP key (switch position) and ZERO key (add number).	Press SET key once to display 01in-d.
Press UNIT key to switch parameters.	As shown, press DISP key to enter, display -199999	Value range -199999~99999 Press SET key to save	As shown, press DISP key to enter, display 000000	Value range -199999~999999 Press SET key to save
As shown, press DISP key to enter, display 999999	Value range -199999~99999 Press SET key to save	As shown, press DISP key to enter, display 000000	Value range 0~999999 Press SET key to save	As shown, the operation is successful, long press SET key to exit.

Remarks:

13mAt Peak Threshold: When the displayed value exceeds the Peak Threshold setting value, peak detection is activated.

14mAb Peak hysteresis: When the displayed value falls back to the set value of the peak hysteresis, peak detection is stopped.

15mint Valley Threshold: When the displayed value is lower than the valley threshold setting, start valley detection.

16minb Valley value hysteresis: When the display value returns to the valley value hysteresis set value, the valley value detection is stopped.

(The value range is set according to the actual situation)

1.8 Switch quantity input function and power-on reset function selection (refer to 7.1.4 of the manual)

Pressure value display interface, long press the SET key (about 2 seconds) to display AL01.	Press ZERO key once to display 990A.	Press DISP key once to display 0000.	Change to 1111 with the DISP key (switch position) and ZERO key (add number).	Press SET key once to display 01in-d.
Press UNIT key to switch parameters	As shown, press DISP key to enter	As shown, press DISP key to enter	Press UNIT key to switch parameters display 19POC	press DISP key to enter
The default is On, press SET key to save.	As shown, the operation is successful, long press SET key to exit.			





Remarks: 19POC When the parameter is On, the meter will be auto zero. When the parameter is OFF, the instrument will not be auto zero.

Chapter 2 Analog Output Parameter Setting

2.1 Analog output parameter setting (30-33)

Example 0-10V ($\pm 10V$) output meter (refer to manual 7.3)

Pressure value display interface, long press the SET key (about 2 seconds) to display AL01.	Press ZERO key once to display 990A.	Press DISP key once to display 0000.	Change to 1111 with the DISP key (switch position) and ZERO key (add number).	Press SET key once to display 01in-d.
long press SET key, display 30AoS	press DISP key to enter, display GroSS	press SET key to save, display 31Aot	press DISP key to enter, display Pn-U($\pm 10V$)	press SET key to save, display 32AotH

				
press DISP key to enter	Enter the upper limit (such as 200), press SET key to save, display 33AotL	press DISP key to enter	Enter the lower limit (- 200), press the SET key to save, and then long press the SET key to exit	

Remarks: The upper and lower limits of the analog output generally correspond to the range of the sensor, and can also be changed as required.





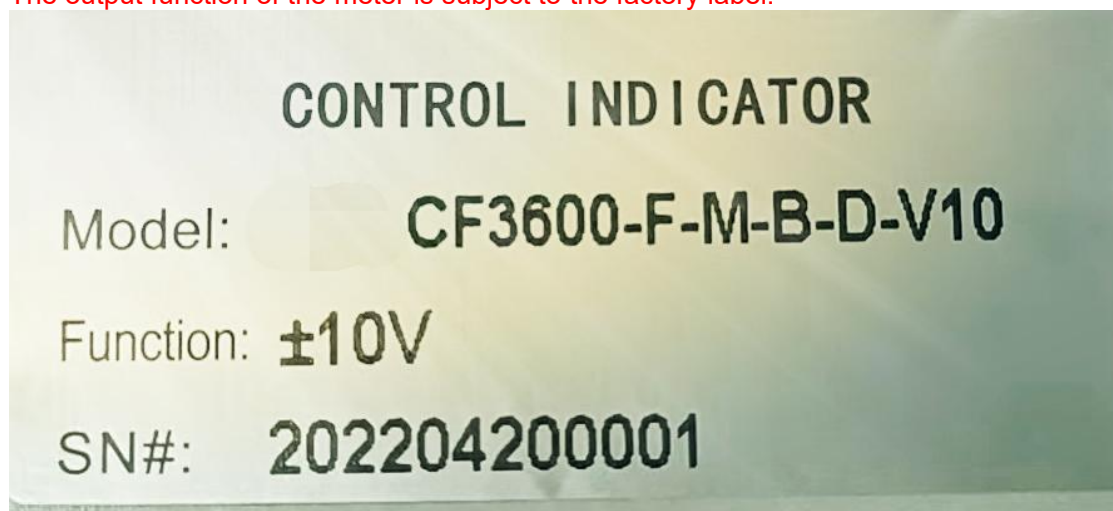





For example, the meter output 4-20MA, 31Aot parameter is changed to 4-20, 32AotH; Enter the range of the sensor (such as +200), 33AotL is changed to 0.









The output function of the meter is subject to the factory label:



Chapter 3 Communication Parameter Set

3.1 Communication parameter set (40-48) (refer to manual 7.4)

				
Pressure value display interface, Press and hold the SET key (about 2s) to display AL01.	Press the ZERO key to display 990A.	Press the DISP key to display 0000.	Change to 1111 with the DISP key (switch position) and ZERO key (add number).	Press the SET key to display 01in-d.
				
Press and hold the SET key to display 40Add	Press DISP key to enter to set the address of the meter	Press SET key to save, display 41bAUd	Press DISP key to enter, set baud rate	Press SET key to save, display 42oES









				
Press DISP key to enter the check digit setting	Default n (no verification), press SET key to save, press UNIT key to switch to display 45Pro	Press the DISP key to enter the setting communication protocol	1. MODBUS-RTU 2. TC ASCII When selecting 1, press the SET key to save	As shown in the figure, the operation is completed, long press the SET key to exit
				
When 2 is selected, press SET to save and display 46Act	Press DISP key to enter setup send mode	1. Command Mode Press SET key to save, then long press SET key to exit	2. Active mode Press SET key to save, then long press SET key to exit	

Remarks: Baud rate range: 2400, 4800, 9600, 19200, 38400, 57600, 115200
Please refer to the manual for communication commands

Chapter 4 Polyline Correction Parameter Setting

4.1 Polyline correction parameter settings (refer to 7.5 of the manual)

				
Pressure value display interface, Press and hold the SET key (about 2 seconds) to display AL01.	Press the ZERO key to display 99.0A.	Press the DISP key to display 0000.	Change to 1111 with the DISP key (switch position) and ZERO key (add number).	Press the SET key to display 01in-d.
				
Press and hold the SET key to display 50FNUM	Press DISP key to enter to set the number of polyline points	Default 03	Up to 10 can be set, press SET key to save, display 51-F1	Press DISP key to enter to set the first point measurement value
				
Default 0	Forexample: Set 90, press SET key	Press DISP key to enter the	Default 0	Forexample: set 100, press SET key

	to save, display 52-S1	setting 1st point standard value		to save, display 53-F2
				
and so on	Press DISP key to enter to set the 10th point measurement value	Default 0	For example: set 190, press SET key to save, display 70-S10	Press DISP key to enter setting 10th point Standard value
				
Default 0	For example: set 200, press SET key to save, display 71FmV	Press DISP key to enter polyline physical quantity selection	Default OFF, press ZERO key to switch to ON	Press SET key to save, then long press SET key to exit

Remarks: The number of broken line correction points can be set to 3-10 points, the measured value is the displayed value of the machine instrument, the standard value is the displayed value of the counter pressure instrument, and record the required sets of data (for example, 50FNUM choose 5 points, then record 5 sets of data), corresponding to the input.

(51-F1 and 52S1 are correction points, and so on, 69-F10 and 70S10 are correction points).

As mentioned above: The 1st point displays 90 before the polyline correction, and displays 100 after the polyline correction;

The 10th point displays 190 before the broken line correction, and displays 200 after discount correction;

















If the error code Error5 is reported, it means that the broken line is wrong.

Purpose: To overcome the problem that the mechanism affects the linearity of the sensor.

Group 5 Parameters		Polyline Correction Parameters		Password 1111		
NO.	Symbols	Name	Name	Add.	Range	directions
50	FNUM	Fnum	Polyline correction segment selection	4FH	0~10	7.5
51	F1	F1	1st point Measured value	50H	-199999~999999	7.5
52	S1	S1	1st point Standard value	51H	-199999~999999	7.5
53	F2	F2	2nd point Measured value	52H	-199999~999999	7.5
54	S2	S2	2nd point Standard value	53H	-199999~999999	7.5
55	F3	F3	3rd point Measured value	54H	-199999~999999	7.5
56	S3	S3	3rd point Standard value	55H	-199999~999999	7.5
57	F4	F4	4th point Measured value	56H	-199999~999999	7.5
58	S4	S4	4th point Standard value	57H	-199999~999999	7.5
59	F5	F5	5th point Measured value	58H	-199999~999999	7.5
60	S5	S5	5th point Standard value	59H	-199999~999999	7.5
61	F6	F6	6th point Measured value	5AH	-199999~999999	7.5
62	S6	S6	6th point Standard value	5BH	-199999~999999	7.5
63	F7	F7	7th point Measured value	5CH	-199999~999999	7.5
64	S7	S7	7th point Standard value	5DH	-199999~999999	7.5
65	F8	F8	8th point Measured value	5EH	-199999~999999	7.5
66	S8	S8	8th point Standard value	5FH	-199999~999999	7.5
67	F9	F9	9th point Measured value	60H	-199999~999999	7.5
68	S9	S9	9th point Standard value	61H	-199999~999999	7.5
69	F10	F10	10th point Measured value	62H	-199999~999999	7.5
70	S10	S10	10th point Standard value	63H	-199999~999999	7.5
71	FmV	FmV	Polyline physical quantity selection	80H	0: oFF / 1: on	7.5

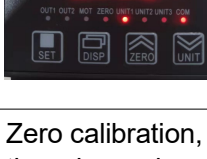
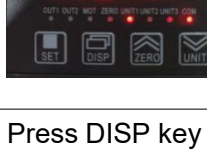
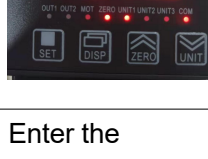
Chapter 5 Calibration Parameter Setting

5.1 Sensitivity calibration (refer to manual 6.3)

				
<p>Pressure value display interface, Press and hold the SET key (about 2s) to display AL01.</p>	<p>Press the ZERO key to display 99.0A.</p>	<p>Press the DISP key to display 0000.</p>	<p>Change to 1111 with the DISP key (switch position) and ZERO key (add number).</p>	<p>Press the SET key to display 01in-d.</p>
				
<p>Press and hold the SET key to display 80CALM</p>	<p>Press DISP key to enter, up and down keys to switch, select TEMP</p>	<p>Press SET to save and display 81CALC</p>	<p>Press UNIT to switch parameters and display 82MV-V</p>	<p>Press DISP key to enter</p>
				
<p>Enter the sensor sensitivity (such as 1.98493), press SET to save, display 83CAL0</p>	<p>Press DISP key to enter</p>	<p>Zero calibration, there is a value display, the value of the pressure sensor can change in the positive direction, after it is stable, press the SET key to save, and display 85CALP</p>	<p>Press DISP key to enter</p>	<p>Enter the sensor range (such as 50.0), press SET to save, and display 86in-A</p>
				

Press UNIT key to switch parameters, display 89Fr	Press DISP key to enter	Enter the sensor range (such as 50.0), press the SET key to save, and then long press to exit, the calibration is complete.		
---	-------------------------	---	--	--

备注： 传感器灵敏度及量程按出厂标签为准

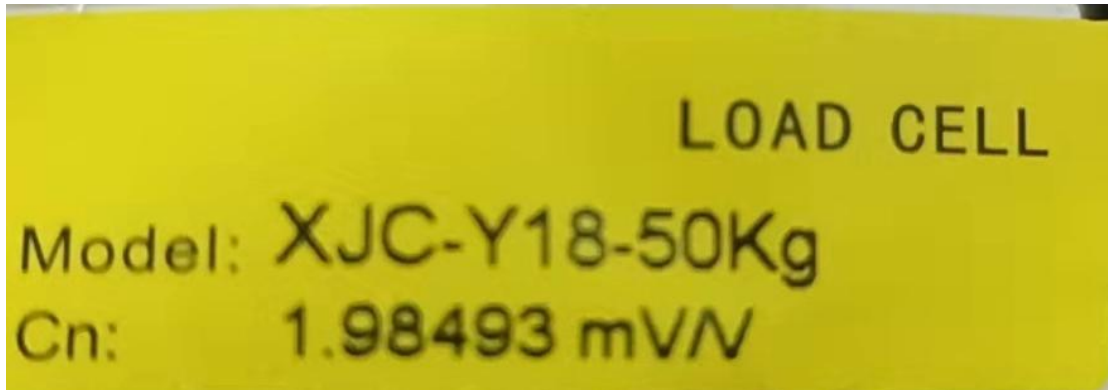









When the sensor is installed and the pressure value is different, the new sensitivity can be converted. The conversion formula is as follows:

The displayed value of the instrument \div the known standard value (the value displayed by the dynamometer or the weight of the weight) \times 82 MV-V parameter value (as shown in the figure above: 1.98493), and then input the 82MV-V parameter to save the new value obtained.

5.2 Weight calibration (refer to Instruction Manual 6.3)

Pressure value display interface, press and hold the SET key (about 2 seconds) to display AL01.	Press the ZERO key to display 990A.	Press the DISP key to display 0000.	Change to 1111 with the DISP key (switch position) and ZERO key (add number).	Press the SET key to display 01in-d.

Press and hold the SET key to display 80CALM	Press DISP key to enter, up and down keys to switch to select norm	Press SET key to save, display 81CALC. Press UNIT key to switch parameters, display 83cAL0	Press DISP key to enter	Zero calibration, there is a numerical display, the value of the pressure sensor can change in the positive direction, after it is stable, press the SET key to save, and display 84CALF
				
Press DISP key to enter	When the sensor is stressed, the value changes accordingly	After stable, press SET key to save, display 85CALP	Press DISP key to enter	Input the force weight of the sensor, (as shown in the figure: 2.0KG weight), then input 2.0, press the SET key to save, and display 88Fd
				
Press UNIT key to switch parameters, display 89Fr	Press DISP key to enter	Enter the sensor range (such as 50.0), press the SET key to save, and then long press to exit, the calibration is complete.		

Note: For gain calibration, the force range of the sensor is from 50% to 80% of the maximum range (depending on the field use)

The instrument displays the error code: ERROR2 When the gain is calibrated (the weight of the sensor) calf < (zero calibration) calo;















ERROR3 The maximum range of the instrument (89fr) is not set properly;

ERROR4 The gain is too low (the weight of the sensor) or the rated putout is too low;

If the above error code is displayed, you can re-calibrate.

Chapter 6 Switch Output Parameter Setting

6.1 Switch output parameter settings (refer to 7.2 of the manual)

				
Pressure value display interface, Press and hold the SET key (about 2 seconds) to display ALO1	Press DISP key to enter, compare mode selection	-HH- is the upper limit output, press SET key to save, display OUT1	Press DISP key to enter, set comparison value	For example, set it to 20.0, press SET key to save, display HYA1
				
Press UNIT key to switch parameters, display ALS1, compare data source selection	Press DISP to enter, the default is Gross (real-time value)	Press SET to save and display ALO2	Press DISP key to enter, choose comparison mode	-LL- is lower limit output, press SET key to save, display OUT2
				
Press DISP to enter, set the comparison value	For example, set to -5.0, press SET key to save, display HYA2	Press UNIT key to switch parameters, display ALS2, compare data source selection	Press DISP to enter, the default is Gross (real-time value)	Press SET to save, then press and hold to exit, the setting is complete

Remarks: Switch output wiring method and use: PD+ power supply 24+ PD- power supply 24-









PD+ and D01 are one output signal (when the displayed pressure \geq OUT1 set value, the OUT1 light is on, and a 24V high-level voltage signal is output).

PD+ and D02 are an output signal (when the displayed pressure \geq OUT2 set value, the OUT2 light is on, and a 24V high-level voltage signal is output).

IO input clear wiring mode: PD+ power supply 24+ PD- power supply 24- PD- and DI are short-circuited to trigger the clear signal (low level)



Chapter 7 User Backup Parameters, Restoring User Backup Parameters, Restoring Factory Defaults

7.1 User backup parameters (refer to manual 7.6)

				
Pressure value display interface, Press and hold the SET key (about 2 seconds) to display ALO1	Press ZERO key to display 99.0A.	Press DISP key to display 0000.	Use the DISP key (to switch positions) and the ZERO key (to add numbers) to change to 2027	Press SET to display UEr
				
Press UNIT to display 915AUE	Press DISP key to enter, display OFF	Press ZERO to change to on	Press the SET key to save, wait for about 2 seconds, then press and hold the SET key to exit, the operation is completed.	

Remarks: After the calibration is completed, the calibration parameters can be saved









7.2 Restore user backup parameters (refer to manual 7.6)

				
Pressure value display interface, Press and hold the SET key (about 2 seconds) to display ALO1	Press ZERO key to display 99.0A.	Press DISP key to display 0000.	Use DISP key (to switch positions) and the ZERO key (to add numbers) to change to 2027	Press SET to display UEr
				

Press UNIT key to switch to display 92odE	Press DISP key to enter, display OFF	Press ZERO to change to on	Press the SET key to save, wait for about 2 seconds, then press and hold the SET key to exit, the operation is completed.	
---	--------------------------------------	----------------------------	---	--

Note: In case of operation error, the backup parameters can be restored

7.3 Restore factory settings (refer to 7.6 of the manual)

				
Pressure value display interface, Press and hold the SET key (about 2 seconds) to display AL01	Press ZERO key to display 99OA.	Press DISP key to display 0000.	Use DISP key (to switch positions) and the ZERO key (to add numbers) to change to 2027	Press SET to display UEr
				
Press UNIT key to switch to display 92odE	Press DISP key to enter, display OFF	Press ZERO to change to on	Press the SET key to save, wait for about 2 seconds, then press and hold the SET key to exit, the operation is completed.	

Remarks: During normal operation, it is not recommended to restore the factory parameter